

600S/660SJ *ALL TERRAIN*

MID-SIZE TRACKED TELESCOPIC BOOM LIFTS



- Rugged tracked all-terrain telescopic boom lifts
- Powerful 4-track drive & oscillating axle
- Independent rubber tracks
- Dual envelope for maximum lift capacities
- Excellent working envelope for maximum versatility

 **snorkel**[™]
www.snorkellifts.com

MID-SIZE TRACKED TELESCOPIC BOOM LIFTS

600S/660SJ ALL TERRAIN

DIMENSIONS	600S ALL TERRAIN*	660SJ ALL TERRAIN*
Max. working height	20.5m	22.1m
Max. platform height (A)	18.5m	20.1m
Max. working outreach	16.0m	17.8m
Platform size	2.44m x 0.91m	2.44m x 0.91m
Transport width	2.24m	2.24m
Overall width (B)	2.46m	2.46m
Transport length	9.2m	8.3m
Overall length (C)	9.2m	10.1m
Transport height	2.61m	3.0m
Stowed height (D)	2.61m	2.61m
Ground clearance	444mm	444mm

PERFORMANCE		
Platform capacity (SWL) unrestricted	272kg	272kg
Platform capacity (SWL) restricted	454kg	454kg
Max. drive height	18.5m	20.1m
Max. wind speed	12.5m/s	12.5m/s
Max. drive speed (stowed)	5.6km/h	5.6km/h
Max. drive speed (elevated)	0.96km/h	0.96km/h
Jib length	n/a	1.67m
Jib arc	n/a	135° (+70°/-65°)
Platform rotation	150°	150°
Turret rotation (continuous)	360°	360°
Raise/lower time	50/50 sec	50/50 sec
Tailswing	1.2m	1.2m
Gradeability	45%	45%
Inside turning radius	5.94m	5.94m
Outside turning radius	8.38m	8.38m
Tires	independent rubber tracks	
Controls	proportional drive, raise, slew, extend, jib & platform rotate	
Drive system	4-track drive	

POWER		
Power source	Deutz 2.9L 55kW/74hp - Tier 4 Final	
Auxiliary power unit	12V DC	12V DC

WEIGHT		
Weight	13,027kg	13,750kg

WORKING ENVELOPES

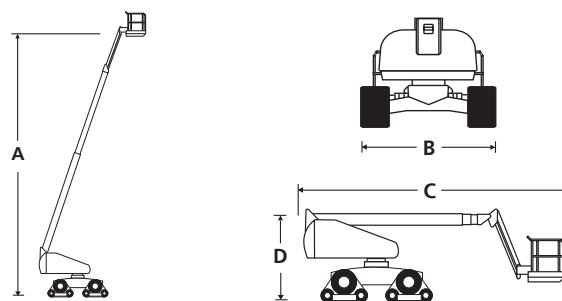
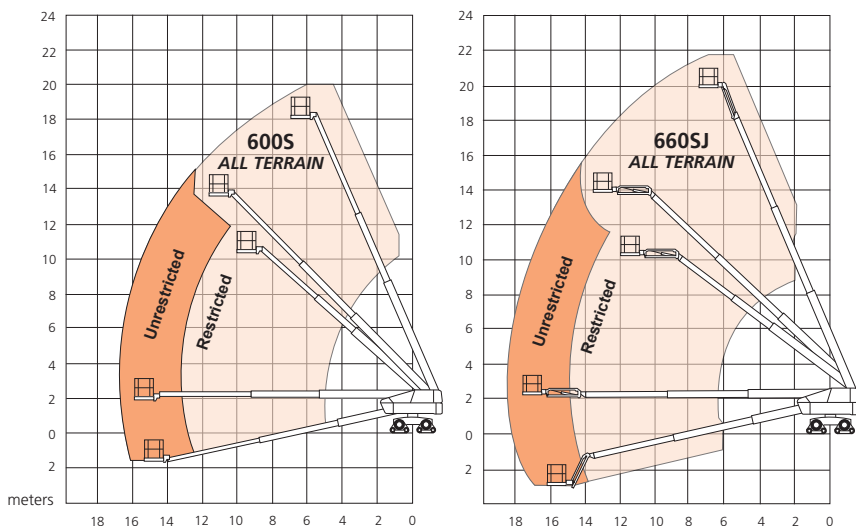

STANDARD FEATURES

- Snorkel Guard™ secondary guarding system
- 1.67m 135° jib (660SJ)
- Oscillating axle (203mm of oscillation)
- Hydraulic platform rotation
- 4-track drive
- All proportional controls
- Swing-out engine tray
- Power line to platform
- Horn
- Motion alarm
- Platform overload system
- 5° tilt alarm & cut-out
- DC emergency operation
- Hydraulic oil cooler
- Tri-entry platform
- Flashing amber light
- Hour meter & on-board diagnostic display
- 2 year parts & labor, 5 year structural warranty
- ANSI compliant

OPTIONS

- Special paint colors
- Airline to platform
- Non-marking tires
- AC generator 110V/220V 2kW
- Aircraft package
- Deluxe aircraft package
- Cold weather package
- Extreme cold weather package
- Extreme environment package
- Light package
- Glazier package
- 10kW generator package
- 10kW generator/welder package
- Environmental hydraulic oil
- Tool tray
- Pipe rack
- Snorkel OnSite™ telematics

snorkel www.snorkellifts.com

P.O. Box 1160
 St. Joseph, MO 64502-1160, USA
 Tel: 1 (785) 989-3000
 Toll-free: 1 (800) 255-0317
 Fax: 1 (785) 989-3070
 Email: sales.usa@snorkellifts.com

ANSI Specification © Snorkel 2021 Specifications subject to change without notice. Photos and diagrams in this brochure are for promotional purposes only. Refer to appropriate Snorkel operators manual for detailed instructions on the proper use and maintenance.
 * Preliminary specifications – confirm at time of ordering.