

# S9031RT-HC/S9043RT-HC

ULTRA-HIGH CAPACITY ROUGH TERRAIN SCISSOR LIFTS

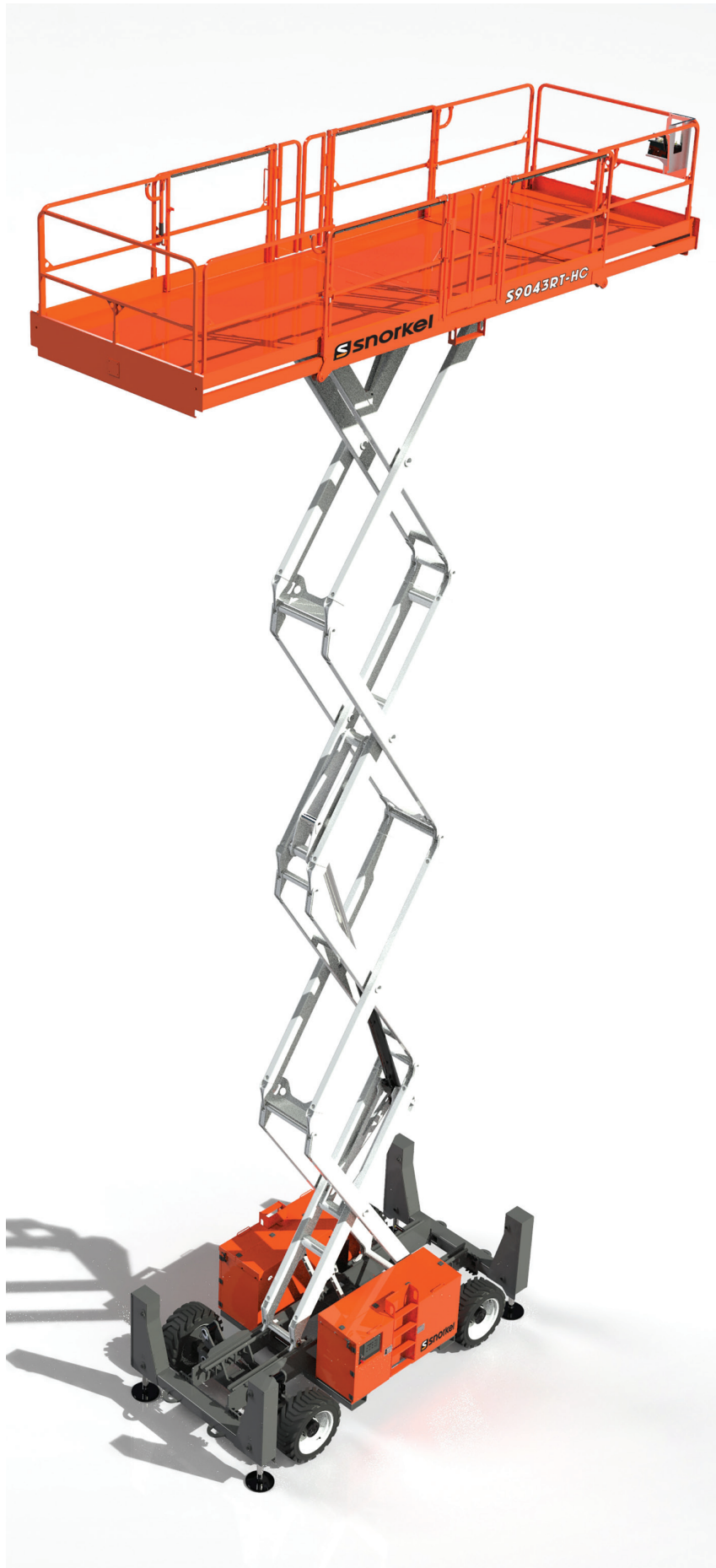

- Ultra-high capacity, large deck rough terrain scissor lifts
- Excellent rough terrain performance
- Heavy duty design
- Dual powered extension decks
- Ideal for construction applications

 **snorkel**<sup>™</sup>  
[www.snorkellifts.com](http://www.snorkellifts.com)

# ULTRA-HIGH CAPACITY ROUGH TERRAIN SCISSOR LIFTS

# S9031RT-HC/ S9043RT-HC

DIMENSIONS	S9031RT-HC*	S9043RT-HC*
Max. working height	11.4m	15.1m
Max. platform height (A)	9.4m	13.1m
Platform size (stowed)	2.28m x 4.87m	
Platform size (dual decks extended)	2.28m x 8.23m	
Extension deck length	1.37m	1.37m
Overall width (B)	2.28m	2.28m
Overall length (D)	4.87m	4.87m
Stowed height (C)	2.77m	2.77m
Min. height (guardrails folded)	1.9m	1.9m
Ground clearance	356mm	356mm

PERFORMANCE	S9031RT-HC*	S9043RT-HC*
Platform capacity (SWL)	1,814kg	1,587kg
Max. drive height	9.4m	13.1m
Max. wind speed	12.5m/s	12.5m/s
Max. drive speed (stowed)	6.7km/h	6.7km/h
Max. drive speed (elevated)	0.96km/h	0.96km/h
Raise/lower time	30/20 sec	40/25 sec
Gradeability	50%	50%
Max. stabilizer levelling, front to rear	6°	6°
Max. stabilizer levelling, side to side	12°	12°
Inside turning radius	2.4m	2.4m
Outside turning radius	5.6m	5.6m
Tyres	13 x 36 foam filled	
Controls	proportional joystick	
Drive system	4-wheel drive	

POWER	S9031RT-HC*	S9043RT-HC*
Power source	Kubota diesel engine	

WEIGHT	S9031RT-HC*	S9043RT-HC*
Weight	6,803kg	7,711kg

## TURNING RADIUS

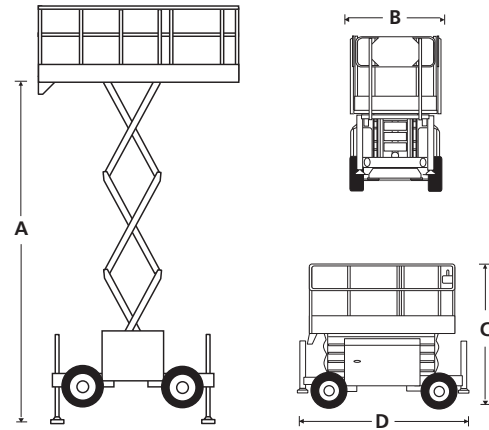
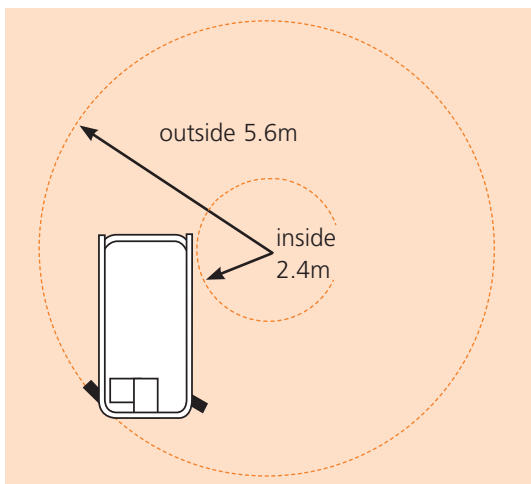

## STANDARD FEATURES

- 4-wheel drive
- 4 hydraulic stabilizers with automatic levelling
- Dual powered extension decks
- Proportional controls
- Foam filled tyres
- Power line to platform
- Drive motion alarm
- Descent alarm
- Fold-down guardrails
- Locking oscillating axle
- Manual lowering valve
- Flashing amber light
- Dual lanyard attachment points
- Hour meter & on-board diagnostics display
- 2 year parts & labour, 5 year structural warranty
- CE approved

## OPTIONS

- Special paint colours
- Nylon spreader pads (set of 4)
- Environmental hydraulic oil
- Cold weather package (block heater + battery warm up)
- Hydraulic generator 110V/240V
- 12kW generator package
- Snorkel OnSite™ telematics

**snorkel** [www.snorkellifts.com](http://www.snorkellifts.com)

Vigo Centre, Birtley Road,  
Washington, Tyne & Wear,  
NE38 9DA, U.K.

t: +44 (0) 845 1550 057

e: sales.emea@snorkellifts.com

01/2022