

# S2770BE/S3370BE/S3970BE

## COMPACT BI-ENERGY ROUGH TERRAIN SCISSOR LIFTS



- Compact bi-energy scissor lifts
- Suitable for interior and exterior use
- Non-marking, high grip tires
- Easy to operate
- Ideal for construction sites

 **snorkel**<sup>™</sup>  
[www.snorkellifts.com](http://www.snorkellifts.com)

# COMPACT BI-ENERGY RT SCISSOR LIFTS

# S2770BE/ S3370BE/S3970BE

DIMENSIONS	S2770BE	S3370BE	S3970BE
Max. working height	10.1m	12.0m	13.8m
Max. platform height (A)	8.1m	10.0m	11.8m
Platform size (stowed) (B)	1.6m x 2.8m	1.6m x 2.8m	1.6m x 2.8m
Platform size (extended) (C)	1.6m x 4.0m	1.6m x 4.0m	1.6m x 4.0m
Extension deck length	1.2m	1.2m	1.2m
Overall width (D)	1.8m	1.8m	1.8m
Stowed length (E)	3.4m	3.4m	3.4m
Stowed height (F)	2.61m	2.7m	2.95m
Min. height (guardrails folded)	1.83m	2.0m	2.13m
Ground clearance	330mm	330mm	330mm

PERFORMANCE	S2770BE	S3370BE	S3970BE
Platform capacity (SWL)	580kg	454kg	350kg
Max. drive height	8.1m	10.0m	11.8m
Max. wind speed	12.5m/s	12.5m/s	12.5m/s
Max. drive speed (stowed)	4.5km/h	4.5km/h	4.5km/h
Max. drive speed (elevated)	0.5km/h	0.3km/h	0.3km/h
Raise/lower time	26/30 sec	50/60 sec	50/60 sec
Gradeability (engine)	35%	35%	30%
Gradeability (battery)	25%	25%	25%
Max. outrigger levelling, front to rear	6°	6°	6°
Max. outrigger levelling, side to side	10°	10°	10°
Inside turning radius	2.7m	2.7m	2.7m
Outside turning radius	5.0m	5.0m	5.0m
Tires	27 x 10.5 foam filled, non-marking		
Controls	proportional joystick		
Drive system	4-wheel drive		

POWER	S2770BE	S3370BE	S3970BE
Power source	Kubota D-902 water-cooled diesel 22.5hp Tier 4 Final and 4 x 6v 305Ah batteries		

WEIGHT	S2770BE	S3370BE	S3970BE
Weight	3,186kg	3,919kg	4,090kg

## TURNING RADIUS

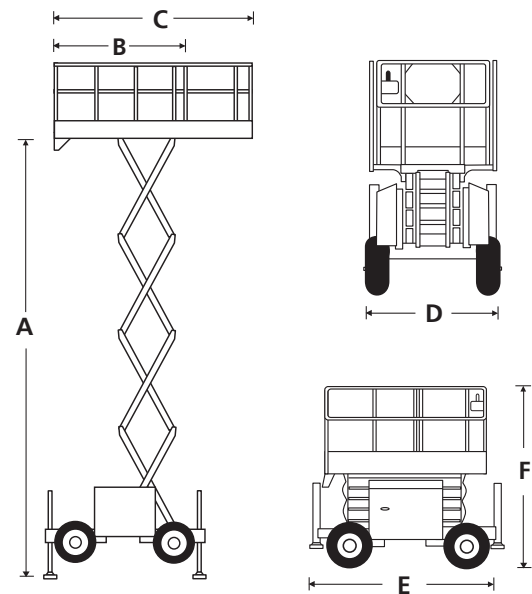
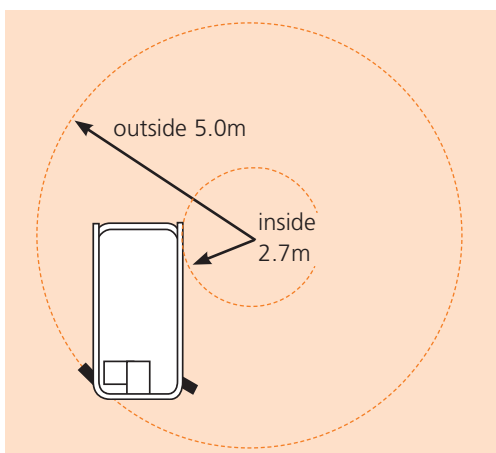

## STANDARD FEATURES

- DC and diesel power - for indoor & outdoor work
- 4-wheel drive
- 4 hydraulic outriggers with automatic levelling
- Roll-out deck extension
- Non-marking foam filled tires
- Proportional controls
- Flashing amber light (x2)
- Oscillating axle
- Power line to platform
- Platform overload system
- Drive motion alarm
- Descent alarm
- Fold-down guardrails
- Hour meter & on-board diagnostics display
- Dual lanyard attachment points
- Manual lowering valve
- 2 year parts & labor, 5 year structural warranty
- ANSI compliant

## OPTIONS

- Special paint colors
- Hydraulic generator 110V 2kW
- Nylon spreader pads (set of 4)
- Environmental hydraulic oil
- Snorkel OnSite™ telematics

**snorkel** [www.snorkellifts.com](http://www.snorkellifts.com)

P.O. Box 1160  
St. Joseph, MO 64502-1160, USA  
Tel: 1 (785) 989-3000  
Toll-free: 1 (800) 255-0317  
Fax: 1 (785) 989-3070  
Email: sales.usa@snorkellifts.com