

Technical sheet :

# **MLT 737-130 PS+**

---



 **MANITOU**  
HANDLING YOUR WORLD

Capacities		Metric
Max. capacity	Q	3700 kg
Max. lifting height	h3	6.90 m
Max. outreach		3.90 m
Reach at max. height		1 m
Breakout force with bucket		6236 daN
Weight and dimensions		
Unladen weight (with forks)		7650 kg
Ground clearance	m4	0.41 m
Wheelbase	y	2.81 m
Overall length to carriage (with hitch)	l11	4.97 m
Overall length to carriage (without hitch)	l3	4.80 m
Front overhang		1.21 m
Overall width	b1	2.39 m
Overall cab width	b4	0.95 m
Overall height	h17	2.38 m
Tilt-down angle	a5	134 °
Tilt-up angle	a4	12 °
External turning radius (over tyres)	Wa1	3.93 m
Standard tires		Alliance - A580 - 460/70 R24 159A8
Drive wheels (front / rear)		2 / 2
Steering wheels (front / rear)		2 / 2
Performances		
Lifting		6.80 s
Lowering		7.10 s
Extension		5.80 s
Retraction		5.20 s
Crowd		3.20 s
Dump		2.80 s
Engine		
Engine brand		Deutz
Engine nom		Stage V
Engine model		TCD 3.6 L4
Number of cylinders - Capacity of cylinders		4 - 3621 cm³
I.C. Engine power rating / Power		129 Hp / 95 kW
Max. torque / Engine rotation		500 Nm @1600 rpm
Drawbar pull (Laden)		7800 daN
Reversible fan		Standard
Engine cooling system		4 radiators (water + intercooler + hydraulic oil + transmission oil)
HVO validated (according to EN 15940 standard)		Yes
Transmission		
Transmission type		Torque converter
Gearbox		Powershift
Number of gears (forward / reverse)		6 / 3
Max. travel speed (may vary according to applicable regulations)		40 km/h
Differential lock		Limited slip differential on front axle
Parking brake		Automatic negative parking brake
Service brake		Oil-immersed multi-discs braking on front & rear axles
Hydraulics		
Hydraulic pump type		Variable displacement pump
Hydraulic flow - Pressure		150 l/min - 270 bar
Flow sharing distributor		Standard
Tank capacities		
Hydraulic oil		135 l
Fuel tank		120 l
Diesel Exhaust fluid (AdBlue® type)		10 l
Noise and vibration		
Noise at driving position (LpA) tested following NF EN 12053 nom		72 dB
Noise to environment (LwA)		105 dB
Vibration to whole hand/arm		< 2.50 m/s²
Miscellaneous		
Tractor homologation		Tractor homologation
Safety cab homologation		ROPS - FOPS level 2 cab
Controls		JSM

## Optional tires tab

Optional tires	Overall height	Overall width
FIRESTONE - R8000 UT - 460/70 R24 159A8	2.39 m	2.42 m
TRELLEBORG - TH400 - 460/70 R24 159A8	2.37 m	2.40 m
TRELLEBORG - TH400 - 500/70 R24 164A8	2.39 m	2.42 m
MICHELIN - XMCL - 500/70 R24 164A8	2.39 m	2.43 m
MICHELIN - BIBLOAD - 460/70 R24 159A8	2.37 m	2.40 m
MICHELIN - BIBLOAD - 500/70 R24 164A8	2.39 m	2.43 m
MICHELIN - XHA - 15.5 R25 158A2	2.37 m	2.40 m
NOKIAN - TRI STEEL - 460/65 R24 156A8	2.36 m	2.40 m
MICHELIN - XMCL - 460/70 R24 159A8	2.37 m	2.40 m
VREDESTEIN - ENDURION - 460/70 R24 159A8	2.38 m	2.41 m
VREDESTEIN - ENDURION - 500/70 R24 164A8	2.41 m	2.44 m
TRELLEBORG - TH500 - 460/70 R24 159A8	2.37 m	2.40 m
ALLIANCE - A585 - 460/70 R24 159A8	2.37 m	2.40 m

## Options / Finishing

S : Standard / O : Optional / - : Not available

	Classic	Premium	Elite
<b>Lifting function</b>			
Attachment hydraulic locking	O	O	O
Intelligent hydraulics	O	O	O
Regenerative Hydraulics	O	O	O
<b>Operator station</b>			
*Active CRC* boom suspension	O	O	S
Air conditioning with automatic adjustment	O	O	S
Air suspension cloth-covered seat (GRAMMER)	O	S	-
Automatic wheel alignment	O	O	S
Bluetooth USB car radio with extra microphone (100 W)	O	O	S
Bluetooth USB car radio with integrated microphone (100 W)	O	S	-
Electric mirror with de-icing	O	O	S
Extra front wiper	O	S	S
Harmony screen	S	S	-
HighView camera	O	O	O
Low frequency air suspension cloth-covered seat (GRAMMER)	O	O	S
Low frequency air suspension cloth-covered seat with heating (GRAMMER)	O	O	O
Manual air conditioning	O	S	-
Mechanical cloth-covered seat (GRAMMER)	S	-	-
SafeView camera pack (x2)	O	O	O
Storage box behind the seat	O	O	O
Tuner car radio (50 W)	S	-	-
Vision screen 7"	O	O	S
<b>Motorization/Power</b>			
Continuous flow hydraulics	O	O	S
Hand throttle	O	O	S
<b>Secondary functions</b>			
Automatic Greasing System (AGS) - chassis	O	O	O
<b>Lighting</b>			
LED+ (4 extra work lights)	O	O	O
LED front road lights (x2)	O	O	O
LED front work lights on cab (x2)	O	S	S
LED rear work lights on cab (x2)	O	S	S
LED work lights on the boom (x2)	O	O	O
Work lights on cab (x4)	S	-	-

MLT 737-130 PS+ - Dimensional drawing

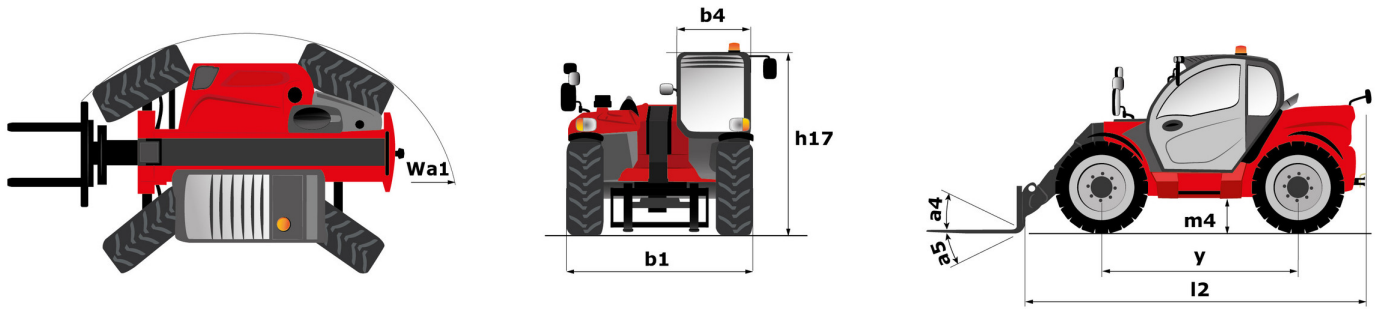

MLT 737-130 PS+ - Load chart

Machine on tyres with forks Metric

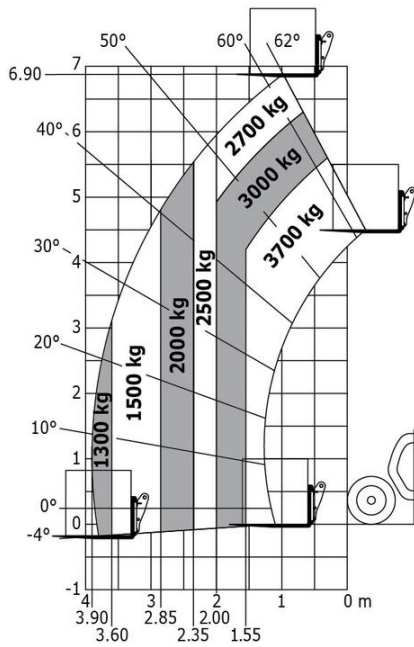



**Head Office**

B.P. 249 - 430 rue de l'Aubinière

44150 Ancenis Cedex - France

Tel: +33 (0)2 40 09 10 11 - Fax: +33 (0)2 40 09 10 97

[www.manitou.com](http://www.manitou.com)



This publication provides a description of the configuration versions and options for Manitou products, which may differ for equipment. The equipment presented in this brochure may be part of a series, as an option, or it may not be available, depending on the versions. Manitou reserves the right, at any time and without notice, to amend the specifications described and represented. The specifications provided do not bind the manufacturer. For more details, please contact your Manitou agent. This is not a contractually binding document. The presentation of the products is not contractually binding. List of specifications non-exhaustive. The logos as well as the visual identity of the company are owned by Manitou and cannot be used without authorisation. All rights reserved. The photos and diagrams contained in this brochure are only provided for consultation and information purposes.

MANITOU BF SA - Limited company with board of directors - Share capital: 39,668,399 euros - 857 802 508 RCS Nantes